



# CH-507RXWPL

HDMI over Single CAT5e/6/7 Wall-plate Receiver



## Operation Manual



## **DISCLAIMERS**

The information in this manual has been carefully checked and is believed to be accurate. Cypress Technology assumes no responsibility for any infringements of patents or other rights of third parties which may result from its use.

Cypress Technology assumes no responsibility for any inaccuracies that may be contained in this document. Cypress also makes no commitment to update or to keep current the information contained in this document.

Cypress Technology reserves the right to make improvements to this document and/or product at any time and without notice.

## **COPYRIGHT NOTICE**

No part of this document may be reproduced, transmitted, transcribed, stored in a retrieval system, or any of its part translated into any language or computer file, in any form or by any means—electronic, mechanical, magnetic, optical, chemical, manual, or otherwise—without express written permission and consent from Cypress Technology.

© Copyright 2011 by Cypress Technology.

All Rights Reserved.

## **TRADEMARK ACKNOWLEDGMENTS**

All products or service names mentioned in this document may be trademarks of the companies with which they are associated.





## SAFETY PRECAUTIONS

Please read all instructions before attempting to unpack, install or operate this equipment and before connecting the power supply.

Please keep the following in mind as you unpack and install this equipment:

- Always follow basic safety precautions to reduce the risk of fire, electrical shock and injury to persons.
- To prevent fire or shock hazard, do not expose the unit to rain, moisture or install this product near water.
- Never spill liquid of any kind on or into this product.
- Never push an object of any kind into this product through any openings or empty slots in the unit, as you may damage parts inside the unit.
- Do not attach the power supply cabling to building surfaces.
- Use only the supplied power supply unit (PSU). Do not use the PSU if it is damaged.
- Do not allow anything to rest on the power cabling or allow any weight to be placed upon it or any person walk on it.
- To protect the unit from overheating, do not block any vents or openings in the unit housing that provide ventilation and allow for sufficient space for air to circulate around the unit.

## REVISION HISTORY

VERSION NO.	DATE (DD/MM/YY)	SUMMARY OF CHANGE
RDV1	13/01/15	Preliminary Release
RDV2	20/01/15	Updated Text & Diagrams
RDV3	25/07/19	Update Format and Cable Distance



# CONTENTS

<b>1. Introduction</b> .....	<b>1</b>
<b>2. Applications</b> .....	<b>1</b>
<b>3. Package Contents</b> .....	<b>1</b>
<b>4. System Requirements</b> .....	<b>1</b>
<b>5. Features</b> .....	<b>2</b>
<b>6. Operation Controls and Functions</b> .....	<b>3</b>
6.1 Receiver Front Panel.....	3
6.2 Receiver Rear Panel .....	4
6.3 IR Cable Pin Assignment.....	4
<b>7. Connection Diagram</b> .....	<b>5</b>
Option 1: Point to Point.....	5
Option 2: Matrix System.....	6
<b>8. Specifications</b> .....	<b>7</b>
8.1 Technical Specifications .....	7
8.2 Cable Specifications .....	8
<b>9. Acronyms</b> .....	<b>9</b>





## 1. INTRODUCTION

The HDMI over Single CAT5e/6/7 Wall-plate Receiver is designed to receive uncompressed video, audio and IR control data from a compatible transmitter over a single run of CAT5e/6/7 cable at a distance of up to 70 meters at 1080p or 40 meters at 4K. It has the added benefit of control through the built-in IR ports. Additionally, it can be powered by a compatible transmitter unit via the Power over Cable (PoC) functionality allowing for greater flexibility in installations.

## 2. APPLICATIONS

- Extend an HDMI signal to a remote location
- Household entertainment sharing and control
- Showroom display and control
- Classroom display and control

## 3. PACKAGE CONTENTS

- 1×HDMI over Single CAT5e/6/7 Wall-plate Receiver
- 1×IR Extender
- 1×Operation Manual

## 4. SYSTEM REQUIREMENTS

- HDMI equipped source device (connected with HDMI cables) or DVI equipped source (connected with DVI to HDMI cables)
- HDMI equipped display (TV or monitor) or an HDMI equipped AV receiver, connected with HDMI cables
- Industry standard CAT5e/6/7 cable
- Compatible PoC HDBaseT™ Receiver

## 5. FEATURES

- HDMI 1.x and DVI 1.0 compliant
- HDCP compliant
- Supports HDMI 3D and 4K x 2K features
- Supports HDCP repeater and CEC bypass
- Supports distance up to 70m/229ft at 1080p and 40m/131ft at 4K through CAT5e/6/7 cable
- HDMI input resolutions up to 4K@60Hz (YUV 4:2:0, 8-bit) or 4K@30Hz (YUV 4:4:4, 8-bit)
- Supports pass-through of audio formats including LPCM 2.0/5.1/7.1, and Bitstream over HDMI
- Easy to install wall plate design

### Note:

1. *This system was tested with CAT6/23AWG and CAT5e/24AWG cables, results may vary with cables of a different specification.*
2. *The PoC function requires a compatible Transmitter unit. Transmitters from other brands may not be compatible.*
3. *For playback of 4K2K HDMI source signals, a 4K2K capable display and High Speed HDMI cables are required.*

## 6. OPERATION CONTROLS AND FUNCTIONS

### 6.1 Receiver Front Panel

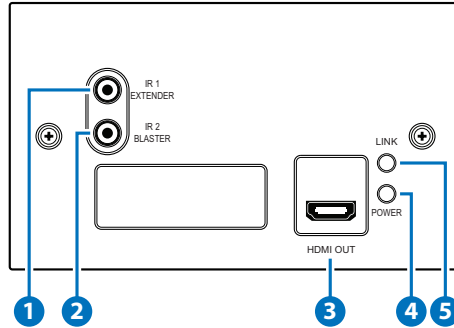

- 1 IR 1 EXTENDER:** Connect an IR Extender cable for IR signal reception. Signals received will be transmitted to the transmitter unit. Ensure that the remote being used is within the direct line-of-sight of the IR Extender.
- 2 IR 2 BLASTER:** Connect an IR Blaster cable for IR signal transmission. IR signals received by an IR extender connected to the transmitter unit will be transmitted by this blaster. Place the IR Blaster in direct line-of-sight of the equipment to be controlled.
- 3 HDMI OUT:** Connect to a HDMI equipped TV/monitor for display of the HDMI source signal.
- 4 POWER LED:** This LED will illuminate when the device is connected and powered by a compatible transmitter unit via PoC.
- 5 LINK LED:** This LED will illuminate when both the source connected to the transmitter and the display connected to the receiver are connected.



## 6.2 Receiver Rear Panel

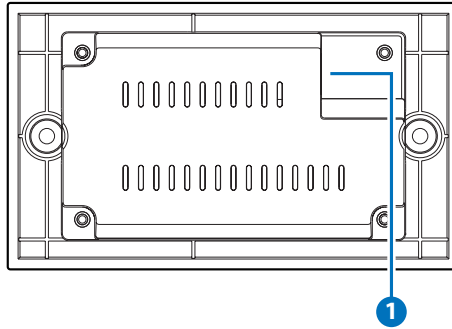

- 1 **CAT5e/6/7 IN:** Connect to the transmitter unit with a single CAT5e/6/7 cable for transmission of all data signals.

## 6.3 IR Cable Pin Assignment

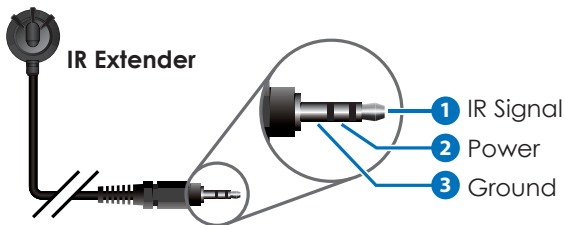
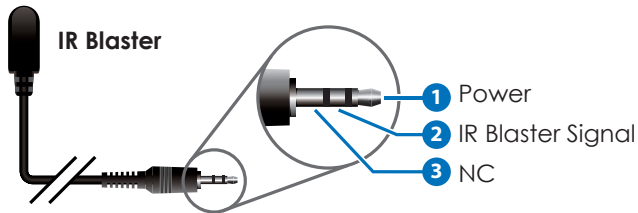

## 7. CONNECTION DIAGRAM

### Option 1: Point to Point

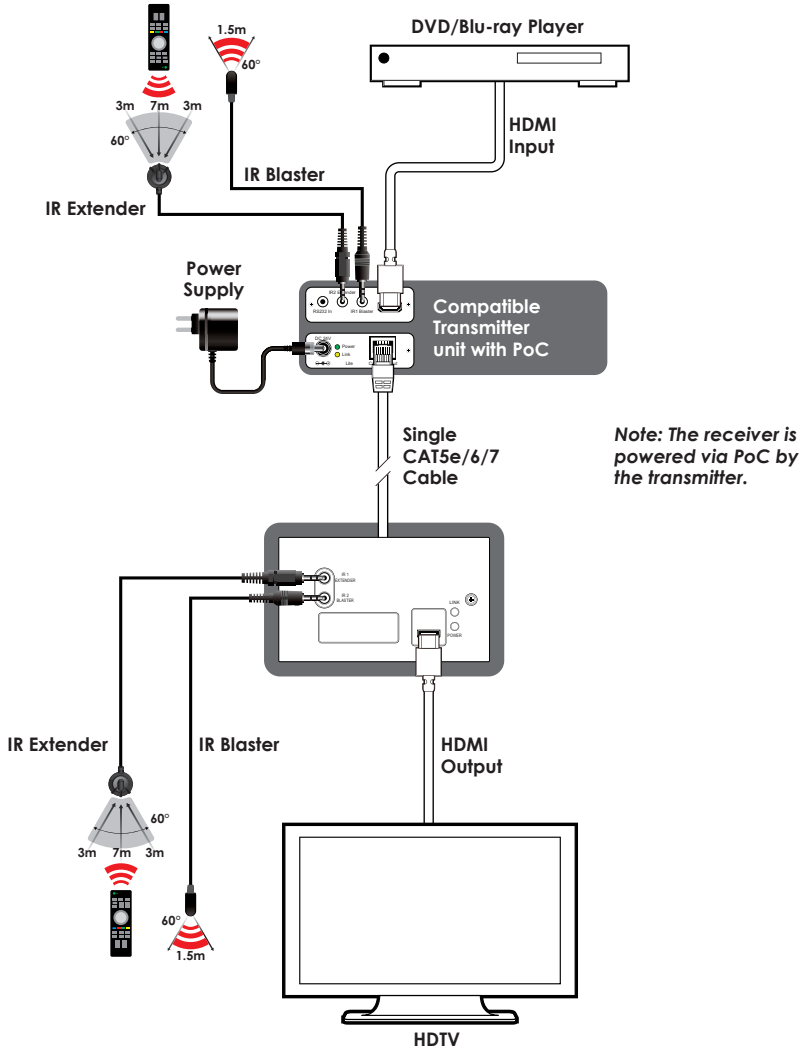

## Option 2: Matrix System

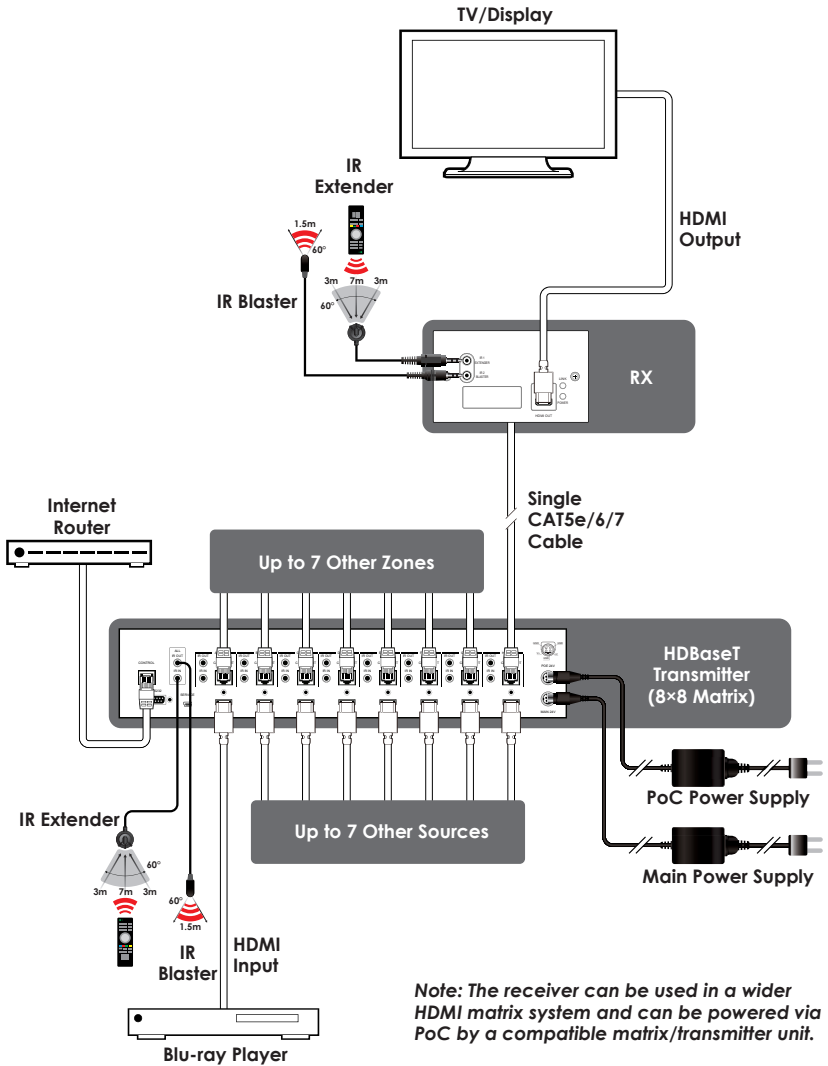



## 8. SPECIFICATIONS

### 8.1 Technical Specifications

<b>Video Bandwidth</b>	300MHz/9 Gbps
<b>Input Ports</b>	1×CAT5e/6/7, 1×IR Extender
<b>Output Ports</b>	1×HDMI, 1×IR Blaster
<b>IR Frequency</b>	30 - 50kHz (30 - 60kHz under ideal conditions)
<b>Baud Rate</b>	up to 115200/sec
<b>ESD Protection</b>	Human-body Model: ±8kV (air-gap discharge) ±4kV (contact discharge)
<b>Dimensions</b>	145.7 mm (W)×85.7 mm (D)×36.5 mm (H)/ Jacks Excluded 145.7 mm (W)×85.7 mm (D)×39.5 mm (H)/ Jacks Included
<b>Weight</b>	160g
<b>Chassis Material</b>	Plastic
<b>Color</b>	White
<b>Operating Temperature</b>	0°C~40°C/32°F~104°F
<b>Storage Temperature</b>	-20°C~60°C/-4°F~140°F
<b>Relative Humidity</b>	20~90% RH (non-condensing)
<b>Power Consumption</b>	12 W (PoC), 9 W (Main)

## 8.2 Cable Specifications

Cable Length	1080p		4K30	4K60
	8-bit	12-bit	(4:4:4) 8-bit	(4:2:0) 8-bit
High Speed HDMI Cable				
HDMI Input	15m	10m	5m	5m
HDMI Output	15m	10m	5m	5m
Ethernet Cable				
Cat.5e/6/7	100m		70m	

- **1080p (FHD Video)**
  - Up to 1080p@60Hz, 12-bit color
  - Data rates lower than 5.3Gbps or below 225MHz TMDS clock
- **4K30 (UHD Video)**
  - 4K@24/25/30Hz & 4K@50/60Hz (4:2:0), 8-bit color
  - Data rates higher than 5.3Gbps or above 225MHz TMDS clock but below 10.2Gbps



## 9. ACRONYMS

ACRONYM	COMPLETE TERM
<b>CAT5e</b>	Category 5 Cable
<b>CAT6</b>	Category 6 Cable
<b>CEC</b>	Consumer Electronics Control
<b>DVI</b>	Digital Visual Interface
<b>HDCP</b>	High-bandwidth Digital Content Protection
<b>HDMI</b>	High Definition Multimedia Interface
<b>IR</b>	Infrared





**CYPRESS TECHNOLOGY CO., LTD**

Home page: <http://www.cypress.com.tw>